

**Part Number: PT278-35050**  
**|| PT278-35130**

**Kit Contents**

Item #	Quantity Req'd.	Description
1	1	LH Base Rail Assembly w/xbar
2	1	RH Base Rail Assembly
3	1	Hardware Bag
4	2	Brackets
5	1	Front Crossbar Assembly

**Hardware Bag Contents**

Item #	Quantity Req'd.	Description
1	4	M6 x 15.7mm Wafer HD Screws
2	6	M6 x 37mm Pan HD Screws
3	1	Instruction Sheet
4	1	Operator Caution Card
5	1	M6 Pivot Hinge Screw
6	10	Washers
7	4	M6 x 15.7mm Pan HD Screws

**Additional Items Required For Installation**

Item #	Quantity Req'd.	Description
1		

**Conflicts**

--

**Recommended Tools**

<b>Personal &amp; Vehicle Protection</b>	<b>Notes</b>
Safety Goggles	
Wrist & Belt Buckle Protectors, Blankets	
<b>Special Tools</b>	<b>Notes</b>
Tape Cutting Tool	IADS P/N: TAC05-014-01
<b>Installation Tools</b>	<b>Notes</b>
T25 & T30 Torx Driver (Hardened)	i.e.; WihaTools.com, Snap-on, Mac...
Torque Wrench	0-150 lbf-in
Awl	
Nylon Panel Removal Tool	e.g. Panel Pry Tool #1 Toyota SST# 00002-06001-01
Extension	3"
<b>Special Chemicals</b>	<b>Notes</b>
None	

**General Applicability**

All D-Cab Tacoma Models
-------------------------

**Recommended Sequence of Application**





Item #	Accessory
1	

\*Mandatory

**Vehicle Service Parts** (may be required for reassembly)

Item #	Quantity Req'd.	Description
1		

**Legend**

	<b>STOP:</b> Damage to the vehicle may occur. Do not proceed until process has been complied with.
	<b>OPERATOR SAFETY:</b> Use caution to avoid risk of injury.
	<b>CAUTION:</b> A process that must be carefully observed in order to reduce the risk of damage to the accessory/vehicle and to ensure a quality installation.
	<b>TOOLS &amp; EQUIPMENT:</b> Used in Figures calls out the specific tools and equipment recommended for this process.
	<b>REVISION MARK:</b> This mark highlights a change in installation with respect to previous issue.

Care must be taken when installing this accessory to ensure damage does not occur to the vehicle. The installation of this accessory should follow approved guidelines to ensure a quality installation.

These guidelines can be found in the "Accessory Installation Practices" document.

This document covers such items as:-

- Vehicle Protection (use of covers and blankets, cleaning chemicals, etc.).
- Safety (eye protection, rechecking torque procedure, etc.).
- Vehicle Disassembly/Reassembly (panel removal, part storage, etc.).
- Electrical Component Disassembly/Reassembly (battery disconnection, connector removal, etc.).

Please see your Toyota dealer for a copy of this document.

### 1. Remove the Ditch Moldings.

- (a) Pull back the rapguard, about 10” from each side and cut off the excess. Add vehicle protection to the top of the doors and down the side of the vehicle.

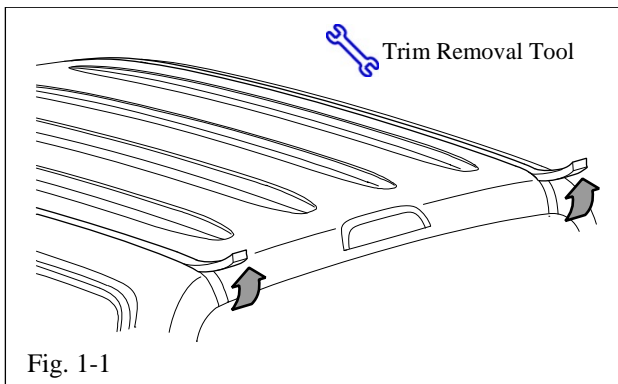

- (b) Carefully remove the ditch moldings from both sides of the vehicle (Fig. 1-1).

- (c) Discard the roof ditch moldings.



- (d) Carefully remove any remaining tape residue at the rear of the ditch above the rear window.

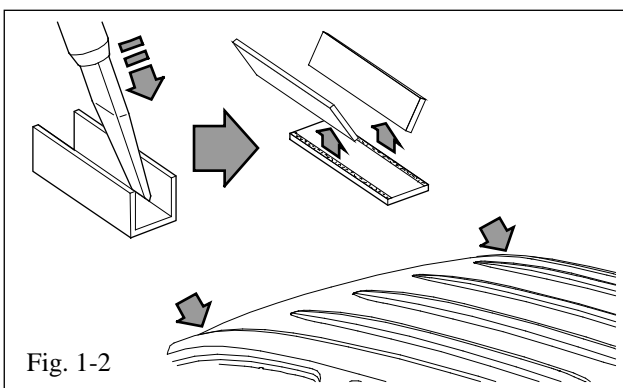

- (e) Use a trim removal tool to break off the vertical walls of the front ditch clips (RH & LH). Wedge the trim removal tool in from the outside then give it a sharp blow with your hand. This should cause the wall to break. Repeat for both sides (Fig. 1-2).

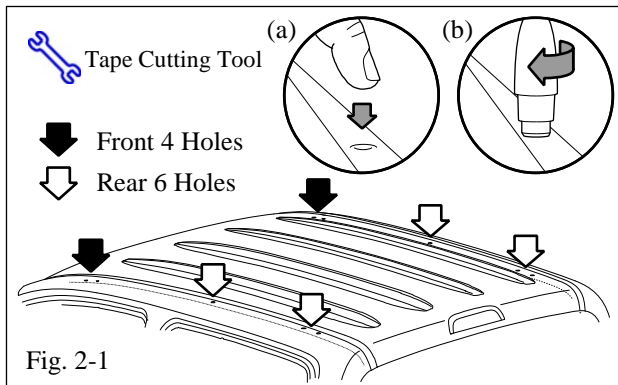

## 2. Prepare the Roof for Rack Installation.

- (a) Use your finger to locate the tape that covers the 10 weldnuts (5 LH & 5 RH) and press down to create a dimple at the location (Fig. 2-1).



- (b) Use the special tape cutting tool to center the tool over the dimple area on the FRONT 4 HOLES ONLY (2 RH & 2 LH). Press down firmly on the tool to expose the knife edge. Rotate the cylinder in one direction. Lift up the tool to expose the weld nut. Dispose of the seal material slug (Fig. 2-1).

## 3. Install the RH & LH Side Roof Rack Brackets.

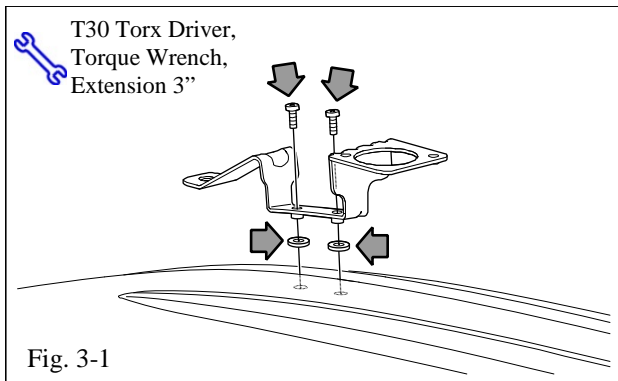

- (a) Remove the adhesive backing & install washers on the bottom of the bracket holes (Fig.3-1).

- (b) Install the bracket as shown (Fig. 3-1).



- (c) Install two short pan head screws (with the pink thread lock); tighten to 13.3 N.m (117.7 lbf-in) (Fig. 3-1).

**Torque: 13.3 N.m (117.7 lbf-in)**



- (d) Center the special tape cutting tool over the dimple area on the REAR 6 HOLES (3 RH & 3 LH). Press down firmly on the tool to expose the knife edge. Rotate the cylinder in one direction. Lift up the tool to expose the weld nut. Dispose of the seal material slug (Fig. 2-1).



(e) Ensure AT LEAST 5 MINUTES has elapsed since the front bracket screws were torqued before proceeding to the next step.



(f) RETORQUE the front bracket screws to 13.3 N.m (117.7 lbf-in) (Fig. 3-1).

**Torque: 13.3 N.m (117.7 lbf-in)**

#### 4. Install the RH Side Roof Rack.

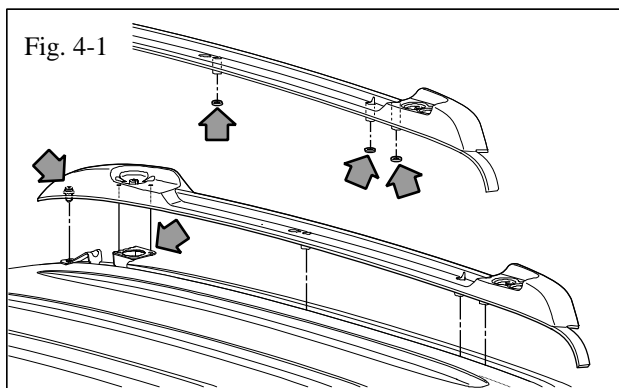

(a) The RH side roof rack does not have the crossbar pre-assembled. Remove the adhesive backing and install 3 washers onto the bottom surface mounting posts then place it on the roof (Fig. 4-1).

(b) Align the assembly so that the pad nose fits into the ditch and is snug against the front window lace (Fig. 4-1).

(c) Visually align the yellow clip at the front above the hole in the bracket. Use the palm of your hand and strike it firmly to seat it in place (Fig. 4-1).

(d) Hand start the three long pan head screws (with the green thread lock) into the roof rack along the roof ditch (Fig. 4-2).

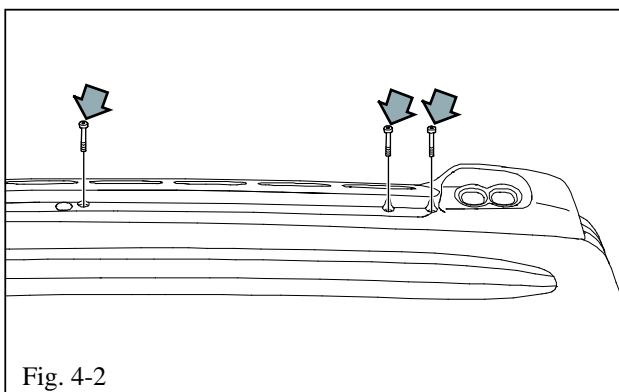

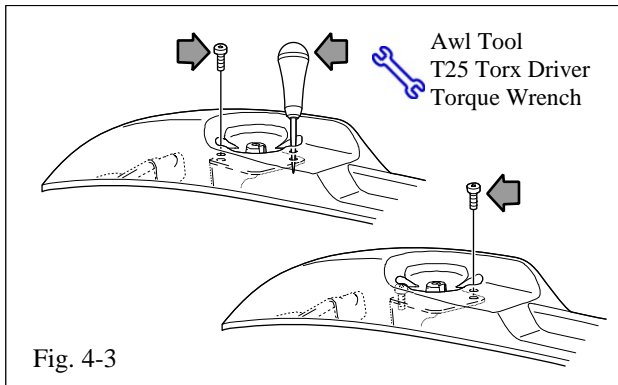

- (e) Use an awl to center the bracket hole below the access hole in the roof rail. Install the first wafer head screw (with the blue thread lock) and tighten. Install the second wafer head screw. Torque the two short wafer head screws to 5.6 N-m (50 lbf-in) (Fig. 4-3).

**Torque: 5.6 N-m (50 lbf-in)**

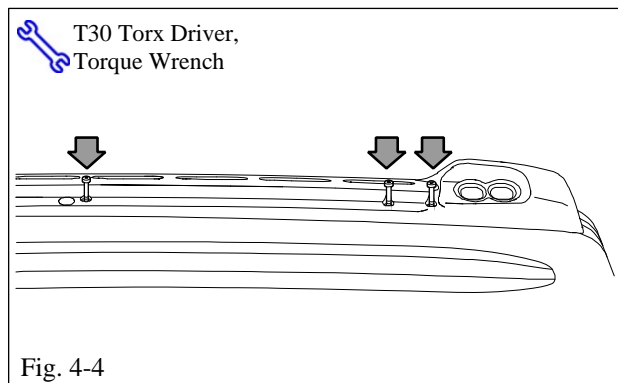

- (f) Torque the three long pan head screws to 13.3 N-m (117.7 lbf-in) (Fig. 4-4)

**Torque: 13.3 N.m (117.7 lbf-in)**

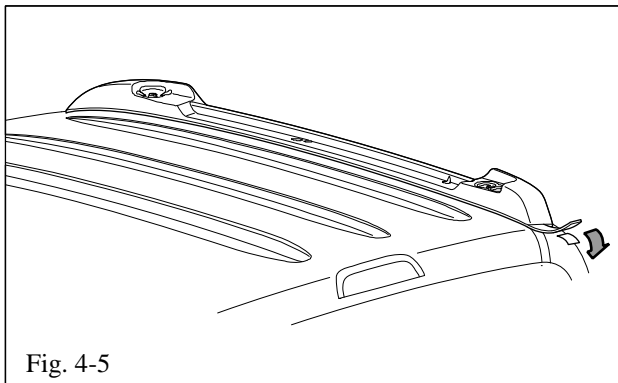

- (g) Align the stub on the rear of the pad with the roof ditch. Once aligned, remove the tape backing and press down firmly. Tuck the stub under the rear window lace (Fig. 4-5).

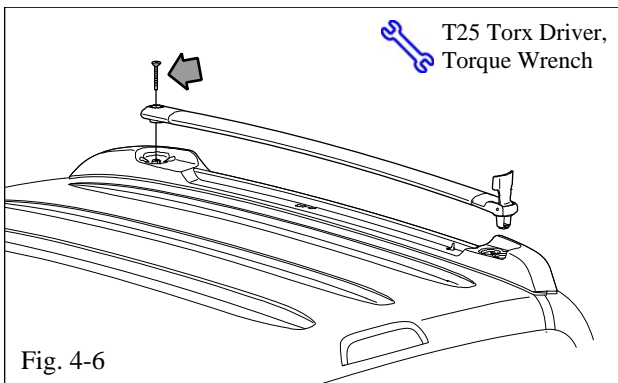

- (h) Install the crossbar assembly to the roof rack (Fig. 4-6).

- (i) Install the Torx head pivot bolt and torque it to 5.6 N-m (50 lbf-in) (Fig. 4-6).

**Torque: 5.6 N-m (50 lbf-in)**

**STOP CAUTION:** Be careful NOT to apply too much downward force while torquing the screw as you may push the tap plate out of the holder in the rail below (Fig 4-6).

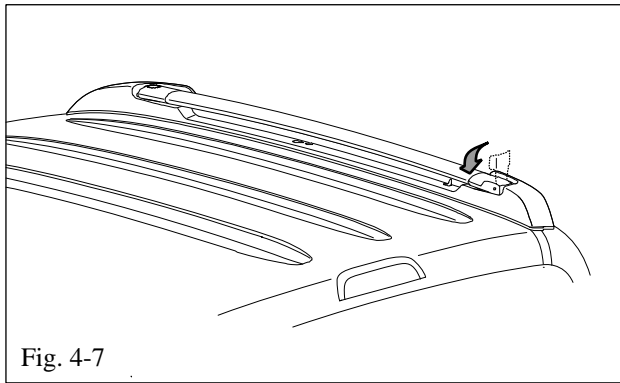

- (j) Ensure the crossbar is secure by lowering the lever (Fig. 4-7).

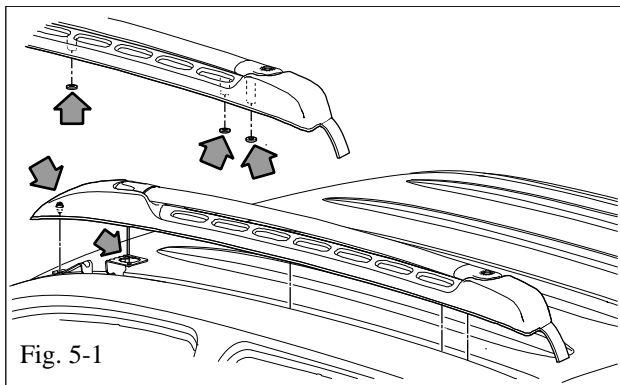

**5. Install the LH Side Roof Rack.**

- (a) The LH side roof rack has the crossbar preassembled. Remove the adhesive backing and install 3 washers onto the bottom surface mounting posts then place it on the roof (Fig. 5-1).
- (b) Align the assembly so that the pad nose fits into the ditch and snug against the front window lace (Fig. 5-1).
- (c) Visually align the yellow clip at the front above the hole in the bracket. Use the palm of your hand and strike it firmly to seat it in place (Fig. 5-1).

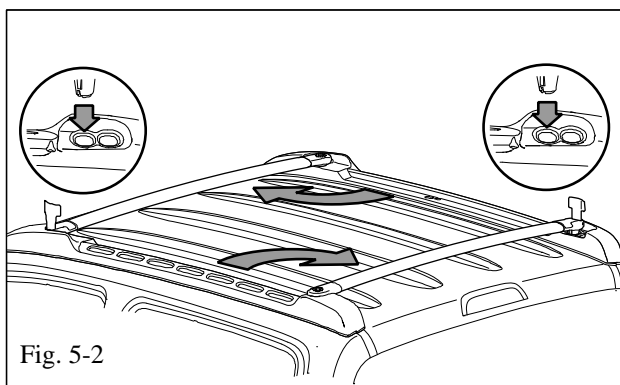

- (d) Lift the LH & RH crossbar levers into the open position and rotate the crossbars so they rest on the base rails as shown. Do not latch them at this time (Fig. 5-2).

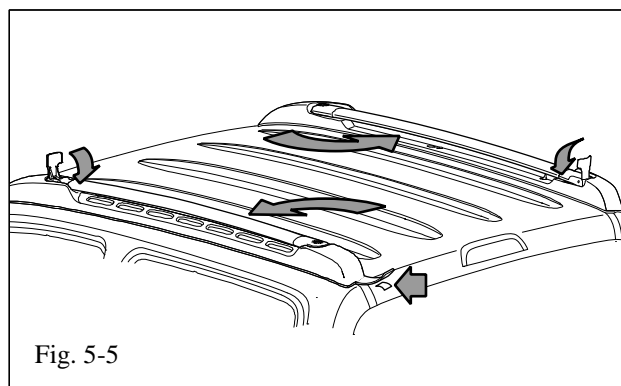
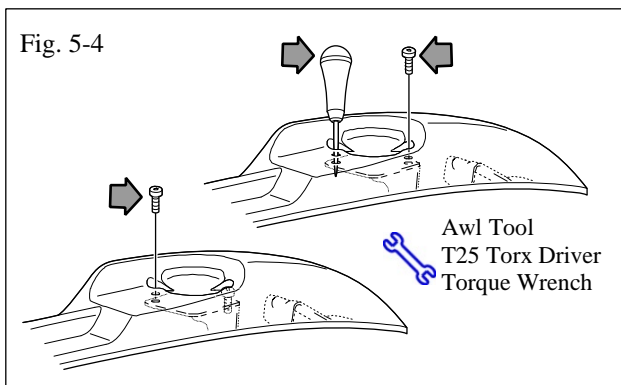
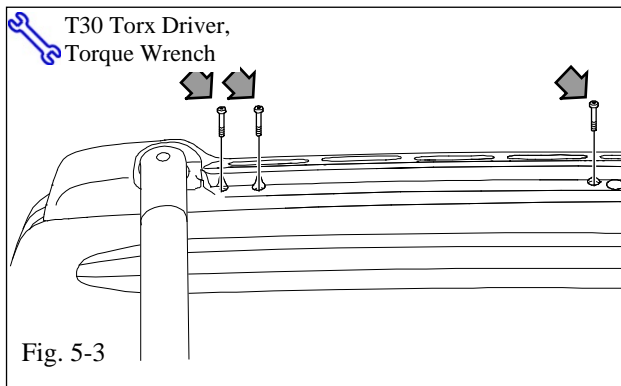

- (e) Hand start the three long pan head screws (with the green thread lock) into the roof rack along the roof ditch (Fig. 5-3).
- (f) Rotate the crossbar from the LH front rail to access the front screw holes.

- ⚠ (g) Use an awl to center the bracket hole below the access hole in the roof rail. Install the first wafer head screw (with the blue thread lock) and tighten. Install the second wafer head screw. Torque the two short wafer head screws to 5.6 N-m (50 lbf-in) (Fig. 5-4).

**Torque: 5.6 N-m (50 lbf-in)**

- ⚠ (h) Torque the three long pan head screws into the roof rack along roof ditch to 13.3 N-m (117.7 lbf-in) (Fig. 5-3)

**Torque: 13.3 N.m (117.7 lbf-in)**

- (i) Align the stub on the rear of the pad with the roof ditch. Once aligned, remove the tape backing and press down firmly. Tuck the stub under the rear window lace (Fig. 5-5).
- (j) Reposition the crossbars into the base rails and close the levers as shown. Ensure the latch is engaged by pulling up on the crossbar above the latch (Fig. 5-5).

- ⚠ (k) Place the 3"x5" roof rack caution card into the owner's manual.

Checklist - these points **MUST** be checked to ensure a quality installation.

<u>Check:</u>	<u>Look For:</u>
<p><u>Accessory Function Checks</u></p> <ul style="list-style-type: none"><li><input type="checkbox"/> Ensure crossbars will install and lock into the deployed (cross-car) position</li><li><input type="checkbox"/> Crossbars should be securely locked into base rails (stowed) for shipment</li><li><input type="checkbox"/> Gap between roof rack side rail pads and vehicle roof surface</li></ul>	<p>Crossbars to lock into the deployed (cross-car) position securely</p> <p>Crossbars securely locked into base rails (stowed)</p> <p>Not greater than 1.5 mm.</p>
<p><u>Vehicle Function Checks</u></p> <ul style="list-style-type: none"><li><input type="checkbox"/> None Required</li></ul>	
<p><u>Vehicle Appearance Check</u></p> <ul style="list-style-type: none"><li><input type="checkbox"/> After accessory installation and removal of protective cover(s), perform a visual inspection.</li></ul>	<p>Ensure no damage (including scuffs and scratches) was caused during the installation process. (For PPO installations, refer to TMS Accessory Quality Shipping Standard.)</p>